

THIS DRAWING IS UNPUBLISHED. RELEASED FOR PUBLICATION
 © COPYRIGHT BY TYCO ELECTRONICS CORPORATION. ALL RIGHTS RESERVED.

LOC	DIST	REVISIONS			
P	LTR	DESCRIPTION	DATE	DWN	APVD
G	14	N	REV PER 0G3A-0582-04	02SEP04	JR TM

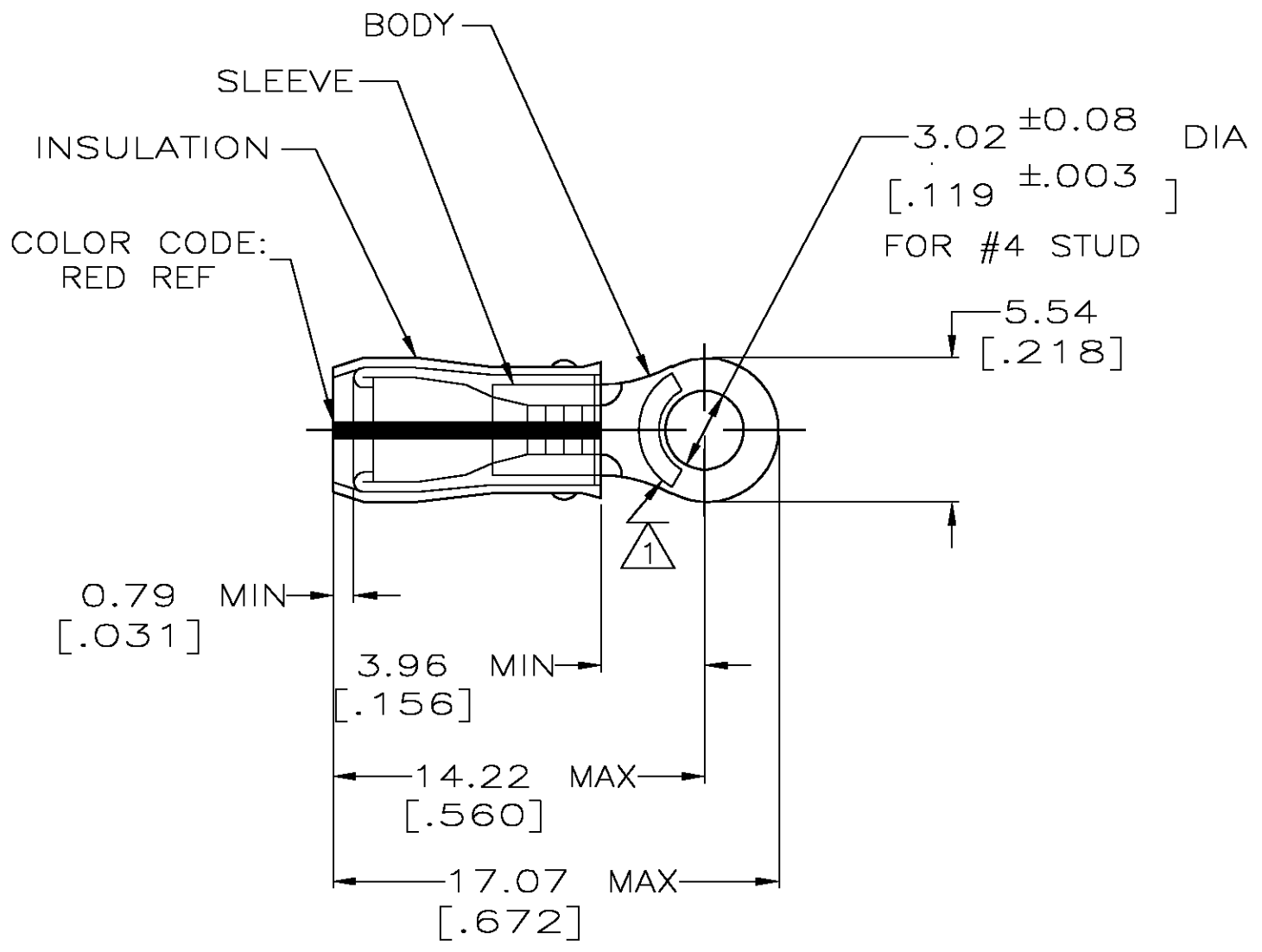

- 1 STAMP AMP 22-18* APPROX AS SHOWN
22-16 TERMINALS ARE STAMPED 22-18 IN ACCORDANCE WITH MILITARY SPEC MIL-T-7928 COMMERCIAL WIRE RANGE IS 22-16
- 2 WIRE INSULATION DIA: .080 - .125
- 3 TONGUE MATERIAL THK: 0.79 ±0.05 [.031 ±0.002]
- 4 TIN/LEAD (93-7) PLATE PER ASTM B545. (3% MIN LEAD CONTENT)
- 5 GOLD PL PER ASTM B488, TYPE 2, GRADE C, OVER NICKEL PER (QQ-N-290).
- 6 SUPERSEDED BY 53405-1
- 7 MATERIAL: BODY & SLEEVE- CU PER ASTM B152 INSULATION - PVF2, COLOR - NATURAL

-	4	100	LOOSE PIECE, BOX	8-53405-1
-	-	-	LOOSE PIECE	53405-5 6
-	5	-	LOOSE PIECE	53405-3
M 7928/4-148 CLASS 1 & 2	4	-	LOOSE PIECE	53405-1
MILITARY P/N & CLASS	FINISH	QTY	PACKAGE TYPE	PART NO.

AMP INCORPORATED CUSTOMER SERVICE SYSTEMS

MAX RECOMMENDED OPERATING TEMPERATURE: 150°C MAX

VOLTAGE RATING: N/A

CIRCULAR MIL AREA: 0.26-1.65mm² [509-3260] STRANDED

FOR ADDITIONAL PRODUCT INFORMATION OR COPIES OF DRAWINGS AND TECHNICAL DOCUMENTS: PRODUCT INFORMATION CENTER 1-800-522-6752

FOR APPLICATION TOOLING INFORMATION: TOOLING ASSISTANCE CENTER 1-800-722-1111

FOR ORDER ENTRY: 1-800-526-5142

THIS DRAWING IS A CONTROLLED DOCUMENT FOR AMP INCORPORATED. IT IS SUBJECT TO CHANGE AND THE CONTROLLING ENGINEERING ORGANIZATION SHOULD BE CONTACTED FOR THE LATEST REVISION.

THIS DRAWING IS A CONTROLLED DOCUMENT.

DIMENSIONS: MM [INCHES]

TOLERANCES UNLESS OTHERWISE SPECIFIED:

0 PLC	± -
1 PLC	± -
2 PLC	± 0.20 [.008]
3 PLC	± -
4 PLC ANGLES	± -

MATERIAL: 7

FINISH: BODY: SEE TABLE 4; SLEEVE: SEE NOTE 4

DWN DK SCHRUM 06/16/93

CHK RE HERSEY 7/6/93

APVD M BARNABA 7/6/93

NAME: Tyco Electronics Corporation, Harrisburg, Pa 17105-3608

PRODUCT SPEC: 108-11023

APPLICATION SPEC: NOT AVAILABLE

WEIGHT: -

SIZE: A3

CAGE CODE: 00779

DRAWING NO: C-53405

RESTRICTED TO: -

SCALE: 4:1

SHEET: 1 OF 1

REV: N

CUSTOMER DRAWING